



User Guide

Reversible air/water "Split Inverter" heat pump

HPI S

MIT-S 4-8/E

MIT-S 11-16/E

MIT-S 22-27/E

MIT-S 4-8/H

MIT-S 11-16/H

MIT-S 22-27/H





Contents

- 1 Safety instructions and recommendations 4**
 - 1.1 Safety 4
 - 1.2 General instructions 4
 - 1.3 Electrical wiring 5
 - 1.4 Refrigerant safety 5
 - 1.5 Water connections 6
 - 1.6 Recommendations 6
 - 1.7 Specific instructions for service, maintenance and breakdowns 6
 - 1.8 Liabilities 7
- 2 Symbols used in the manual 7**
- 3 Technical specifications 8**
 - 3.1 Homologations 8
 - 3.1.1 Directives 8
 - 3.1.2 EC Declaration of Conformity 8
 - 3.2 Main components 8
 - 3.3 Technical data 8
 - 3.3.1 Heat pump 8
 - 3.3.2 Heat pump weight 10
 - 3.3.3 Combination heaters with medium-temperature heat pump 11
 - 3.3.4 Circulating pump 14
- 4 Operation 14**
 - 4.1 Description of the user interface 14
 - 4.1.1 Description of the user interface 14
 - 4.1.2 Description of the home screen 14
 - 4.2 Starting and stopping the heat pump 15
 - 4.2.1 Starting the heat pump 15
 - 4.2.2 Shutting down the heat pump 15
 - 4.3 Switching the central heating on/off 15
 - 4.4 Periods of absence or going on holiday 16
 - 4.5 Regional and ergonomic parameters 16
 - 4.6 Personalising the zones 17
 - 4.6.1 Definition of the term "zone" 17
 - 4.6.2 Changing the name and symbol of a zone 17
 - 4.7 Personalising the activities 17
 - 4.7.1 Definition of the term "Activity" 17
 - 4.7.2 Changing the name of an activity 17
 - 4.7.3 Changing the temperature of an activity 18
 - 4.8 Room temperature for a zone 18
 - 4.8.1 Selecting the operating mode 18
 - 4.8.2 Activating and configuring a timer programme for heating 18
 - 4.8.3 Activating and configuring a timer programme for cooling 19
 - 4.8.4 Changing the room temperature temporarily 19
 - 4.9 Domestic hot water temperature 19
 - 4.9.1 Selecting the operating mode 19
 - 4.9.2 Activating and configuring a timer programme for domestic hot water 20
 - 4.9.3 Forcing domestic hot water production (override) 20
 - 4.9.4 Modifying the domestic hot water set point temperatures 20
 - 4.10 Monitoring the energy consumption 21
- 5 Maintenance 21**
 - 5.1 General 21
 - 5.2 Standard inspection and maintenance operations 22
 - 5.3 Maintenance message 22
 - 5.4 Displaying the maintenance information 22
 - 5.5 Check the hydraulic pressure 22
 - 5.6 Cleaning the casing 23
- 6 Troubleshooting 23**
 - 6.1 Resolving operating errors 23
 - 6.1.1 Types of error code 23
 - 6.1.2 Blocking codes 23

6.1.3	SCB-10 blocking codes	24
6.1.4	Lockout codes	26
6.1.5	Warning codes	26
6.1.6	SCB-10 warning codes	27
6.2	Fault finding	27
7	Decommissioning and disposal	28
7.1	Decommissioning procedure	28
7.2	Disposal and recycling	29
8	Energy savings	29
9	Product fiche and package fiche	29
9.1	Compatible heating devices	29
9.2	Product fiche	29
9.3	Product fiche – Temperature controller	31
9.4	Package fiche - Medium-temperature heat pumps	31
10	Appendix	33
10.1	Name and symbol of the zones	33
10.2	Name and temperature of the activities	33

1 Safety instructions and recommendations

1.1 Safety

Operation	<p> Danger This appliance can be used by children aged from 8 years and above and persons with reduced physical, sensory or mental capabilities or lack of experience and knowledge if they have been given supervision or instruction concerning use of the appliance in a safe way and understand the hazards involved. Children shall not play with the appliance. Cleaning and user maintenance shall not be made by children without supervision.</p>
Electrical	<p> Important Before any work on the appliance, carefully read all documents that accompany the product. These documents are also available on our website. See the last page.</p> <p> Warning</p> <ul style="list-style-type: none"> • Install the appliance in accordance with national rules on electrical installation. • If a power supply cable comes with the appliance and it turns out to be damaged, it must be replaced by the manufacturer, its after-sales service or persons with similar qualifications in order to avoid danger. • If the appliance is not wired in the factory, carry out the wiring according to the wiring diagram described in the chapter Electrical Connections. See the Installation and Service Manual. • This appliance must be connected to the protective earthing. • Earthing must comply with the prevailing installation standards. • Earth the appliance before making any electrical connections. • Type and calibre of the protective equipment: refer to the "Recommended cable cross-sections" chapter. See the Installation and Service Manual. • To connect the appliance to the electricity mains, refer to the "Electrical Connections" chapter. See the Installation and Service Manual. <p>In order to avoid the danger of an unexpected thermal circuit breaker reset, this appliance must not be powered through an external switch, such as a timer, or be connected to a circuit which is regularly switched on and off by the electricity provider.</p>
Hydraulics	<p> Caution Respect the minimum and maximum water pressure and temperature to ensure the appliance operates correctly. See chapter on Technical Specifications.</p>
Installation	<p> Important Allow the space required to install the appliance correctly, referring to the "Installation" chapter. See the Installation and Service Manual.</p>

1.2 General instructions

Installation	<ul style="list-style-type: none"> • The system must satisfy each point in the rules in force in the country that govern works and interventions in individual homes, blocks of flats or other buildings. • Only qualified professionals are authorised to work on the appliance and the heating installation. They must respect prevailing local and national regulations during fitting, installation and maintenance of the installation. • Commissioning must be performed by a qualified professional.
---------------------	--

1.3 Electrical wiring

General	<ul style="list-style-type: none"> • Only a qualified installer or qualified service person are allowed to carry out the electrical work of the indoor and outdoor units. Under no circumstances must this work be done by an unqualified individual since failure to carry out the work properly may result in electric shocks and/or electrical leaks. • The appliance must be installed in accordance with national wiring regulations. Capacity shortages in the power supply circuit or an incomplete installation may cause an electric shock or fire.
Precautions	<div style="background-color: #f0f0f0; padding: 5px; border: 1px solid #ccc;">  <p>Danger Before any wiring work on the electrical circuit, switch off the power supply, check that no voltage is present and secure the circuit breaker with a circuit breaker lock-out.</p> </div> <ul style="list-style-type: none"> • Use wiring that meets the specifications in the Installation Manual and the stipulations in the local regulations and laws. Use of wiring which does not meet the specifications may give rise to electric shocks, electrical leakage, smoking and/or a fire. • Always connect a protective earthing cable (grounding). Earthing must comply with the prevailing installation standards. Earth the appliance before making any electrical connections. Incomplete grounding can cause a malfunction or electric shock. • To avoid electric shock, make sure that the length of the conductors between the strain relief device and the terminal blocks is such that the active conductors are put under tension before the earth conductor. • Install a circuit breaker that meets the specifications in the installation manual and the stipulations in the local regulations and laws. • Install the circuit breaker where it can be easily accessed by the technician. • In order to avoid the danger of an unexpected thermal circuit breaker reset, this appliance must not be powered through an external switch, such as a timer, or be connected to a circuit which is regularly switched on and off by the electricity provider. • If a power supply cable comes with the appliance and it turns out to be damaged, it must be replaced by the manufacturer, its after-sales service or persons with similar qualifications in order to avoid danger. • When connecting the appliance to the electricity mains or carrying out any other wiring work, refer to the instructions given in the installation manual and the provided wiring diagrams. • Separate the very low voltage cables from the 230/400 V power supply cables.

1.4 Refrigerant safety

General	<ul style="list-style-type: none"> • France: Pursuant to Article L. 113-3 of the French Consumer Code, the equipment must be installed by a certified operator whenever the refrigerant load is in excess of 5 tonnes of CO₂ equivalent or when a refrigerant connection is necessary (the case with split systems, even when fitted with a quick coupling device). • All work on the refrigeration circuit must be done by a qualified professional, according to prevailing codes of practice and safety in the profession (recovery of the refrigerant, brazing under nitrogen). All brazing work must be done by qualified brazers.
Precautions	<ul style="list-style-type: none"> • Use only R410A refrigerant to fill the installation. • Use tools and pipe components especially designed for use with R410A refrigerant. • Use copper pipes deoxidised with phosphorus to carry the refrigerant. • Store the refrigerant connection pipes away from dust and humidity (risk of damage to the compressor). • Do not use a load cylinder. • Protect the heat pump components, including the insulation and structural elements. Do not overheat the pipes as brazed components may cause damage. • Contact between the refrigerant and a flame may result in emissions of toxic gases. • Do not touch the refrigeration connection pipes with your bare hands while the heat pump is running. Danger of burn or frost injury. • In the event of a refrigerant leakage: <ul style="list-style-type: none"> - Switch off the appliance. - Open the windows. - Do not use a naked flame, do not smoke, do not operate electrical contacts. - Avoid contact with the refrigerant. Danger of frost injuries. - Locate the probable leak and seal it immediately. Use only original parts to replace a defective refrigeration component. • Use only dehydrated nitrogen for detecting leaks or for pressurised tests. • Do not allow the refrigerant to escape into the atmosphere.

1.5 Water connections

General	<ul style="list-style-type: none"> • To drain the domestic hot water circuit. See chapter Maintenance. • Limit temperature at the draw-off point: the maximum domestic hot water temperature at the draw-off point is subject to special regulations in the various countries in which the appliance is sold in order to protect the user. These special regulations be observed when installing the appliance.
Precautions	<ul style="list-style-type: none"> • Insulate the pipes to reduce heat losses to a minimum. • Fit drainage valves between the indoor unit and the heating circuit. • If radiators are connected directly to the heating circuit, make sure that there is enough volume of heating water available in the installation. For example, install a pressure actuated bypass valve and a buffer tank between the indoor unit and the heating circuit. • Respect the minimum and maximum water pressure and temperature (70°C) to ensure the appliance operates correctly. See chapter on Technical Specifications. • The hydraulic installation must be capable of handling a minimum flow rate at all times. • Heating water and domestic water must not come into contact with each other. Domestic water must not circulate through the exchanger.

1.6 Recommendations

Operation	<ul style="list-style-type: none"> • Keep the indoor unit and outdoor unit accessible at all times. • Regularly check the hydraulic pressure in the heating system. • Do not touch radiators for long periods. Depending on the heat pump settings, the temperature of the radiators may exceed 60 °C. • Do not power off the heat pump. The frost protection mode does not work if the heat pump is switched off. • If you do not need to heat your home for a long period, turn off the heating function or activate frost protection mode. See the chapter Selecting the operating mode. • Do not drain the installation, except in cases of absolute necessity, for example at disposal. See the chapter Decommissioning and disposal. • Give preference to the OFF or frost protection mode rather than switching off the system to leave the following functions running: <ul style="list-style-type: none"> - Anti blocking of pumps - Frost protection • Never remove or cover the labels and data plates affixed to appliances. Labels and data plates must be legible throughout the entire lifetime of the appliance. • Immediately replace damaged or illegible instructions and warning stickers. • If you need to switch off the heat pump in the event of a prolonged absence, drain the indoor unit and the heating system to prevent the system from freezing. • Do not make any modifications to the heat pump without the written consent of the manufacturer. • To benefit from warranty cover, no modifications should be made to the appliance.
------------------	--

1.7 Specific instructions for service, maintenance and breakdowns

Precautions	<ul style="list-style-type: none"> • Maintenance work must be carried out by a qualified professional. • Only a qualified professional is authorised to set, correct or replace the safety devices. • For heat pumps with a refrigerant load of more than 5 tonnes of CO₂ equivalent, the user must have an annual leak-tightness test performed on the refrigerant equipment. • Before any work, switch off the power supply to the heat pump, the indoor unit and the hydraulic/electrical backup. • Wait for approx. 20-30 seconds for the outdoor unit capacitors to be discharged, and check that the lights on the outdoor unit PCBs have gone out. • Before working on the refrigeration circuit, switch off the appliance and wait a few minutes. Certain items of equipment such as the compressor and the pipes can reach temperatures in excess of 100 °C and high pressures, which may cause serious injuries. • Use only original spare parts. • Locate and correct the cause of power cut before resetting the safety thermostat. • Removal and disposal of the heat pump must be carried out by a qualified professional in accordance with prevailing local and national regulations. • After maintenance or repair work, check the entire heating system to ensure that there are no leaks. • Remove the casing only to perform maintenance and repair work. Put the casing back in place after maintenance and repair work.
--------------------	---

1.8 Liabilities

Manufacturer's liability	<p>Our products are manufactured in compliance with the requirements of the various Directives applicable. They are therefore delivered with the CE marking and any documents necessary. In the interests of the quality of our products, we strive constantly to improve them. We therefore reserve the right to modify the specifications given in this document.</p> <p>Our liability as manufacturer may not be invoked in the following cases:</p> <ul style="list-style-type: none"> • Failure to abide by the instructions on installing the appliance. • Failure to abide by the instructions on using the appliance. • Faulty or insufficient maintenance of the appliance.
Installer's liability	<p>The installer is responsible for the installation and initial commissioning of the appliance. The installer must observe the following instructions:</p> <ul style="list-style-type: none"> • Read and follow the instructions given in the manuals provided with the appliance. • Install the appliance in compliance with prevailing legislation and standards. • Carry out initial commissioning and any checks necessary. • Explain the installation to the user. • If maintenance is necessary, warn the user of the obligation to check the appliance and keep it in good working order. • Give all the instruction manuals to the user.
User's liability	<p>To guarantee optimum operation of the system, the user must follow the instructions below:</p> <ul style="list-style-type: none"> • Read and follow the instructions given in the manuals provided with the appliance. • Call on a qualified professional to carry out installation and initial commissioning. • Get your installer to explain your installation to you. • Have the required inspections and maintenance carried out by a qualified installer. • Keep the instruction manuals in good condition close to the appliance.

2 Symbols used in the manual

This manual uses various danger levels to draw attention to special instructions. We do this to improve user safety, to prevent problems and to guarantee correct operation of the appliance.



Danger

Risk of dangerous situations that may result in serious personal injury.



Danger of electric shock

Risk of electric shock.



Warning

Risk of dangerous situations that may result in minor personal injury.



Caution

Risk of material damage.



Important

Please note: important information.



See

Reference to other manuals or pages in this manual.

3 Technical specifications

3.1 Homologations

3.1.1 Directives

This product complies with the requirements of the following European Directives and Standards:

- Pressure Equipment Directive 2014/68/EU
- Low Voltage Directive 2014/35/EU
Generic standard: EN 60335-1
Relevant standards: EN 60335-2-40, EN 60335-2-21
- Electromagnetic Compatibility Directive 2014/30/EU
Generic standards: EN 61000-6-3, EN 61000-6-1
Relevant Standard: EN 55014

This product complies with the requirements of European Directive 2009/125/EC on the ecodesign of energy-related products.

In addition to the legal requirements and guidelines, the supplementary guidelines in this manual must also be followed.

Supplements or subsequent regulations and guidelines that are valid at the time of installation shall apply to all regulations and guidelines specified in this manual.

3.1.2 EC Declaration of Conformity

The unit complies with the standard type described in the EC declaration of conformity. It has been manufactured and put into circulation in accordance with the requirements of the European Directives.

The original declaration of conformity is available from the manufacturer.

3.2 Main components

Fig.1

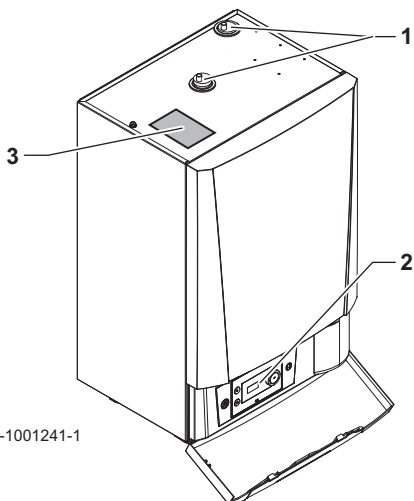

MW-1001241-1

- 1 Automatic air vent
- 2 Control panel
- 3 Location of the data plate

3.3 Technical data

3.3.1 Heat pump

The specifications are valid for a new appliance with clean heat exchangers.

Maximum operating pressure: 0.3 MPa (3 bar)

Tab.1 Outdoor unit conditions of use

Limit operating temperatures	AWHP 4.5 MR	AWHP 6 MR-3	AWHP 8 MR-2	AWHP 11 MR-2 AWHP 11 TR-2	AWHP 16 MR-2 AWHP 16 TR-2	AWHP 22 TR-2	AWHP 27 TR-2
Water in heating mode	+18 °C / +55 °C	+18 °C / +60 °C	+18 °C / +60 °C	+18 °C / +60 °C	+18 °C / +60 °C	+18 °C / +60 °C	+18 °C / +60 °C
Outdoor air in heating mode	-15 °C / +35 °C	-15 °C / +35 °C	-20 °C / +35 °C	-20 °C / +35 °C	-20 °C / +35 °C	-20 °C / +35 °C	-20 °C / +35 °C
Water in cooling mode	+7 °C / +25 °C	+7 °C / +25 °C	+7 °C / +25 °C	+7 °C / +25 °C	+7 °C / +25 °C	+7 °C / +25 °C	+7 °C / +25 °C
Outdoor air in cooling mode	+10 °C / +46 °C	+7 °C / +46 °C	+7 °C / +46 °C	+7 °C / +46 °C	+7 °C / +46 °C	+7 °C / +46 °C	+7 °C / +46 °C

Tab.2 Heating mode: outside air temperature +7 °C, water temperature at the outlet +35 °C. Performances in accordance with EN 14511-2.

Measurement type	Unit	AWHP 4.5 MR	AWHP 6 MR-3	AWHP 8 MR-2	AWHP 11 MR-2	AWHP 11 TR-2	AWHP 16 MR-2	AWHP 16 TR-2	AWHP 22 TR-2	AWHP 27 TR-2
Heat output	kW	4.60	5.87	8.26	10.56	10.56	14.19	14.19	21.70	24.40
Coefficient of performance (COP)	-	5.11	4.18	4.27	4.18	4.18	4.22	4.22	3.96	3.80
Absorbed electrical power	kWe	0.90	1.41	1.93	2.53	2.53	3.36	3.36	5.48	6.42
Nominal water flow rate ($\Delta T = 5$ K)	m ³ /h	0.80	1.04	1.47	1.88	1.88	2.67	2.67	3.80	4.20

Tab.3 Heating mode: outside air temperature +2 °C, water temperature at the outlet +35 °C. Performances in accordance with EN 14511-2.

Measurement type	Unit	AWHP 4.5 MR	AWHP 6 MR-3	AWHP 8 MR-2	AWHP 11 MR-2	AWHP 11 TR-2	AWHP 16 MR-2	AWHP 16 TR-2	AWHP 22 TR-2	AWHP 27 TR-2
Heat output	kW	3.47	3.74	5.93	10.19	10.19	11.38	11.38	16.11	14.70
Coefficient of performance (COP)	-	3.97	3.30	3.12	3.20	3.20	3.22	3.22	3.13	3.13
Absorbed electrical power	kWe	0.88	1.11	1.90	3.19	3.19	3.53	3.53	5.14	4.70

Tab.4 Cooling mode: outside air temperature +35 °C, water temperature at the outlet +7 °C. Performances in accordance with EN 14511-2.

Measurement type	Unit	AWHP 4.5 MR	AWHP 6 MR-3	AWHP 8 MR-2	AWHP 11 MR-2	AWHP 11 TR-2	AWHP 16 MR-2	AWHP 16 TR-2	AWHP 22 TR-2	AWHP 27 TR-2
Cooling output	kW	4.52	4.50	6.65	9.90	9.90	9.74	9.74	11.30	13.20
Energy efficiency ratio (EER)	-	2.77	2.71	3.00	2.77	2.77	2.89	2.89	2.80	2.82
Absorbed electrical power	kWe	1.63	1.66	2.22	3.57	3.57	3.37	3.37	4.07	4.69

Tab.5 Cooling mode: outdoor air temperature +35°C, water temperature at the outlet +18°C. Certified performances at full load in accordance with EN 14511-2.

Measurement type	Unit	AWHP 4.5 MR	AWHP 6 MR-3	AWHP 8 MR-2	AWHP 11 MR-2	AWHP 11 TR-2	AWHP 16 MR-2	AWHP 16 TR-2	AWHP 22 TR-2	AWHP 27 TR-2
Cooling output	kW	6.39	7.41	10.29	15.49	15.49	18.36	18.36	23.23	23.52
Energy efficiency ratio (EER)	-	2.98	2.90	3.15	3.48	3.48	2.81	2.81	2.88	2.85
Absorbed electrical power	kWe	2.14	2.56	3.27	4.45	4.45	6.53	6.53	8.07	8.25

Tab.6 Cooling mode: outdoor air temperature +35°C, water temperature at the outlet +18°C. Stated performances at nominal load in accordance with EN 14511-2.

Measurement type	Unit	AWHP 4.5 MR	AWHP 6 MR-3	AWHP 8 MR-2	AWHP 11 MR-2	AWHP 11 TR-2	AWHP 16 MR-2	AWHP 16 TR-2	AWHP 22 TR-2	AWHP 27 TR-2
Cooling output	kW	3.80	4.69	7.90	11.16	11.16	14.46	14.46	17.65	22.20
Energy efficiency ratio (EER)	-	4.28	4.09	3.99	4.68	4.68	4.43	4.43	3.80	3.80
Absorbed electrical power	kWe	0.89	1.15	2.00	2.35	2.35	3.65	3.65	4.65	5.84

Tab.7 Common specifications

Measurement type	Unit	AWHP 4.5 MR	AWHP 6 MR-3	AWHP 8 MR-2	AWHP 11 MR-2	AWHP 11 TR-2	AWHP 16 MR-2	AWHP 16 TR-2	AWHP 22 TR-2	AWHP 27 TR-2
Total dynamic head at nominal flow rate	kPa	62	61.80	49.30	39.30	39.30	21.30	21.30	-	-
Nominal air flow rate	m ³ /h	2680	2700	3000	6000	6000	6000	6000	8400	8400
Power voltage of the outdoor unit	V	230	230	230	230	400	230	400	400	400
Start-up amperage	A	5	5	5	5	3	6	3	-	-
Maximal amperage	A	12	13	17	29.5	13	29.5	13	19	21
Sound power - Inside ⁽¹⁾	dB(A)	43	43	51	51	51	51	51	43	43
Acoustic power - Outside ⁽²⁾	dB(A)	58	65	65	69	69	69	69	77	77
R410A refrigerant	kg	1.4	1.3	3.2	4.6	4.6	4.6	4.6	7.1	7.7
R410A refrigerant ⁽³⁾	tCO ₂ e	2.923 (2.694)	2.714 (2.501)	6.682 (6.157)	9.605 (8.850)	9.605 (8.850)	9.605 (8.850)	9.605 (8.850)	14.825 (13.660)	16.078 (14.815)
Refrigerant connection (Liquid - Gas)	inch	1/4 - 1/2	1/4 - 1/2	3/8 - 5/8	3/8 - 5/8	3/8 - 5/8	3/8 - 5/8	3/8 - 5/8	3/8 - 1 or 3/8 - 3/4 ⁽⁴⁾	1/2 - 1 or 1/2 - 3/4 ⁽⁴⁾
Maximum precharged length	m	7	10	10	10	10	10	10	30	30

(1) Noise radiated by the envelope - Test run in accordance with the NF EN 12102 standard, temperature conditions: air 7 °C, water 55 °C.

(2) Noise radiated by the envelope - Test run in accordance with the NF EN 12102 standard, temperature conditions: air 7 °C, water 45 °C for AWHP 4.5 MR only (inner and outer sides).

(3) The quantity of refrigerant in tonnes of CO₂ equivalent is calculated using the following formula: quantity (in kg) of refrigerant x GWP/ 1000. The Global Warming Potential (GWP) of the R410A is 2088 following the IPCC fourth assessment report (1924 following IPCC fifth assessment report).

(4) Warning: the refrigerant connection lengths are limited to 20 m with the 3/4" gas pipe.

3.3.2 Heat pump weight

Tab.8 Indoor unit

Indoor unit	Unit	MIT-S 4-8/E	MIT-S 4-8/H	MIT-S 11-16/E	MIT-S 11-16/H	MIT-S 22-27/E	MIT-S 22-27/H
Net weight	kg	59	53	66	60	66	60
Gross weight	kg	70	64	77	71	77	71

Tab.9 Outdoor unit

Outdoor unit	Unit	AWHP 4.5 MR	AWHP 6 MR-3	AWHP 8 MR-2	AWHP 11 MR-2	AWHP 11 TR-2	AWHP 16 MR-2	AWHP 16 TR-2	AWHP 22 TR-2	AWHP 27 TR-2
Weight	kg	54	42	75	118	130	118	130	135	141

3.3.3 Combination heaters with medium-temperature heat pump

Tab.10 Technical parameters for heat pump combination heaters (parameters declared for medium-temperature application)

Product name	Symbol	Unit	AWHP 4.5 MR	AWHP 6 MR-3	AWHP 8 MR-2
Air-to-water heat pump			Yes	Yes	Yes
Water-to-water heat pump			No	No	No
Brine-to-water heat pump			No	No	No
Low-temperature heat pump			No	No	No
Equipped with a supplementary heater			Yes	Yes	Yes
Heat pump combination heater			No	No	No
Rated heat output under average conditions⁽¹⁾	<i>Prated</i>	kW	3	4	6
Rated heat output under colder conditions	<i>Prated</i>	kW	5	4	6
Rated heat output under warmer conditions	<i>Prated</i>	kW	4	5	6
Declared capacity for heating for part load at an indoor temperature of 20 °C and outdoor temperature T_j					
$T_j = -7$ °C	<i>Pdh</i>	kW	3.8	3.4	5.6
$T_j = +2$ °C	<i>Pdh</i>	kW	4.3	2.2	2.9
$T_j = +7$ °C	<i>Pdh</i>	kW	4.5	2.1	6.4
$T_j = +12$ °C	<i>Pdh</i>	kW	5.5	2.6	4.3
$T_j =$ bivalent temperature	<i>Pdh</i>	kW	3.1	3.9	5.6
$T_j =$ operation limit temperature	<i>Pdh</i>	kW	3.1	3.9	5.6
Bivalent temperature	<i>T_{biv}</i>	°C	-10	-10	-10
Degradation coefficient ⁽²⁾	<i>Cdh</i>	-	1.0	1.0	1.0
Seasonal space heating energy efficiency under average conditions	η_s	%	134	125	129
Seasonal space heating energy efficiency under colder conditions	η_s	%	109	116	119
Seasonal space heating energy efficiency under warmer conditions	η_s	%	179	172	169
Declared coefficient of performance or primary energy ratio for part load at an indoor temperature of 20 °C and outdoor temperature T_j					
$T_j = -7$ °C	<i>COPd</i>	-	1.64	1.75	1.95
$T_j = +2$ °C	<i>COPd</i>	-	3.46	3.18	3.22
$T_j = +7$ °C	<i>COPd</i>	-	4.96	4.56	4.57
$T_j = +12$ °C	<i>COPd</i>	-	7.90	6.41	6.55
$T_j =$ bivalent temperature	<i>COPd</i>	-	1.20	1.56	1.70
$T_j =$ operation limit temperature	<i>COPd</i>	-	1.20	1.56	1.70
Operation limit temperature for air-to-water heat pumps	<i>TOL</i>	°C	-10	-10	-10
Heating water operating limit temperature	<i>WTOL</i>	°C	55	60	60
Electrical power consumption					
Off mode	<i>P_{OFF}</i>	kW	0.009	0.009	0.009
Thermostat-off mode	<i>P_{TO}</i>	kW	0.049	0.049	0.049
Stand-by	<i>P_{SB}</i>	kW	0.012	0.016	0.018
Crankcase heater mode	<i>P_{CK}</i>	kW	0.000	0.055	0.055
Supplementary heater					
Rated heat output	<i>P_{sup}</i>	kW	0.0	0.0	0.0
Type of energy input			Electricity	Electricity	Electricity
Other specifications					
Capacity control			Variable	Variable	Variable
Sound power level, indoors - outdoors	<i>L_{WA}</i>	dB	43 - 58	43 - 65	51 - 65

Product name	Symbol	Unit	AWHP 4.5 MR	AWHP 6 MR-3	AWHP 8 MR-2
Annual energy consumption under average conditions	Q_{HE}	kWh	2353	2124	3499
Annual energy consumption under colder conditions	Q_{HE}	kWh	4483	3721	4621
Annual energy consumption under warmer conditions	Q_{HE}	kWh	1249	1492	1904
Rated air flow rate, outdoors for air-to-water heat pumps	-	m ³ /h	2680	2700	3300
(1) The rated heat output P_{rated} is equal to the design load for heating $P_{designh}$, and the rated heat output of a supplementary heater P_{sup} is equal to the supplementary capacity for heating $sup(T_j)$.					
(2) If C_{dh} is not determined by measurement, the default degradation coefficient is $C_{dh} = 0.9$.					

Tab.11 Technical parameters for heat pump combination heaters (parameters declared for medium-temperature application)

Product name	Symbol	Unit	AWHP 11 MR-2 AWHP 11 TR-2	AWHP 16 MR-2 AWHP 16 TR-2
Air-to-water heat pump			Yes	Yes
Water-to-water heat pump			No	No
Brine-to-water heat pump			No	No
Low-temperature heat pump			No	No
Equipped with a supplementary heater			Yes	Yes
Heat pump combination heater			No	No
Rated heat output under average conditions ⁽¹⁾	P_{rated}	kW	6	9
Rated heat output under colder conditions	P_{rated}	kW	4	7
Rated heat output under warmer conditions	P_{rated}	kW	8	13
Declared capacity for heating for part load at an indoor temperature of 20 °C and outdoor temperature T_j				
$T_j = -7$ °C	P_{dh}	kW	6.8	8.6
$T_j = +2$ °C	P_{dh}	kW	5.3	6.5
$T_j = +7$ °C	P_{dh}	kW	9.0	12.9
$T_j = +12$ °C	P_{dh}	kW	7.7	9.9
$T_j =$ bivalent temperature	P_{dh}	kW	6.3	8.8
$T_j =$ operation limit temperature	P_{dh}	kW	6.3	8.8
Bivalent temperature	T_{biv}	°C	-10	-10
Degradation coefficient ⁽²⁾	C_{dh}	-	1.0	1.0
Seasonal space heating energy efficiency under average conditions	η_s	%	125	121
Seasonal space heating energy efficiency under colder conditions	η_s	%	113	113
Seasonal space heating energy efficiency under warmer conditions	η_s	%	167	161
Declared coefficient of performance or primary energy ratio for part load at an indoor temperature of 20 °C and outdoor temperature T_j				
$T_j = -7$ °C	COP_d	-	1.82	1.85
$T_j = +2$ °C	COP_d	-	3.17	3.02
$T_j = +7$ °C	COP_d	-	4.54	4.34
$T_j = +12$ °C	COP_d	-	6.19	5.75
$T_j =$ bivalent temperature	COP_d	-	1.20	1.35
$T_j =$ operation limit temperature	COP_d	-	1.20	1.35
Operation limit temperature for air-to-water heat pumps	TOL	°C	-10	-10
Heating water operating limit temperature	$WTOL$	°C	60	60
Electrical power consumption				
Off mode	P_{OFF}	kW	0.009	0.009
Thermostat-off mode	P_{TO}	kW	0.049	0.035
Stand-by	P_{SB}	kW	0.021	0.021
Crankcase heater mode	P_{CK}	kW	0.055	0.055
Supplementary heater				
Rated heat output	P_{sup}	kW	0.0	0.0

Product name	Symbol	Unit	AWHP 11 MR-2 AWHP 11 TR-2	AWHP 16 MR-2 AWHP 16 TR-2
Type of energy input			Electricity	Electricity
Other specifications				
Capacity control			Variable	Variable
Sound power level, indoors - outdoors	L_{WA}	dB	51 - 65	51 - 69
Annual energy consumption under average conditions	Q_{HE}	kWh	3999	5861
Annual energy consumption under colder conditions	Q_{HE}	kWh	3804	5684
Annual energy consumption under warmer conditions	Q_{HE}	kWh	2580	4120
Rated air flow rate, outdoors for air-to-water heat pumps	-	m ³ /h	6000	6000
(1) The rated heat output P_{rated} is equal to the design load for heating $P_{designh}$, and the rated heat output of a supplementary heater P_{sup} is equal to the supplementary capacity for heating $sup(T_j)$.				
(2) If Cdh is not determined by measurement, the default degradation coefficient is $Cdh = 0.9$.				

Tab.12 Technical parameters for heat pump combination heaters (parameters declared for medium-temperature application)

Product name	Symbol	Unit	AWHP 22 TR-2	AWHP 27 TR-2
Air-to-water heat pump			Yes	Yes
Water-to-water heat pump			No	No
Brine-to-water heat pump			No	No
Low-temperature heat pump			No	No
Equipped with a supplementary heater			Yes	Yes
Heat pump combination heater			No	No
Rated heat output under average conditions ⁽¹⁾	P_{rated}	kW	11	14
Rated heat output under colder conditions	P_{rated}	kW	12	14
Rated heat output under warmer conditions	P_{rated}	kW	18	20
Declared capacity for heating for part load at an indoor temperature of 20 °C and outdoor temperature T_j				
$T_j = -7$ °C	P_{dh}	kW	10.3	12.4
$T_j = +2$ °C	P_{dh}	kW	10.0	8.9
$T_j = +7$ °C	P_{dh}	kW	5.8	11.8
$T_j = +12$ °C	P_{dh}	kW	6.9	18.1
$T_j =$ bivalent temperature	P_{dh}	kW	10.9	12.4
$T_j =$ operation limit temperature	P_{dh}	kW	10.9	14.1
Bivalent temperature	T_{biv}	°C	-10	-7
Degradation coefficient ⁽²⁾	Cdh	-	1.0	1.0
Seasonal space heating energy efficiency under average conditions	η_s	%	114	112
Seasonal space heating energy efficiency under colder conditions	η_s	%	111	103
Seasonal space heating energy efficiency under warmer conditions	η_s	%	143	141
Declared coefficient of performance or primary energy ratio for part load at an indoor temperature of 20 °C and outdoor temperature T_j				
$T_j = -7$ °C	COP_d	-	1.95	1.67
$T_j = +2$ °C	COP_d	-	2.80	2.86
$T_j = +7$ °C	COP_d	-	3.76	4.12
$T_j = +12$ °C	COP_d	-	4.85	5.06
$T_j =$ bivalent temperature	COP_d	-	1.64	1.67
$T_j =$ operation limit temperature	COP_d	-	2.80	2.86
Operation limit temperature for air-to-water heat pumps	TOL	°C	-10	-10
Heating water operating limit temperature	$WTOL$	°C	60	60
Electrical power consumption				
Off mode	P_{OFF}	kW	0.010	0.014
Thermostat-off mode	P_{TO}	kW	0.049	0.023

Product name	Symbol	Unit	AWHP 22 TR-2	AWHP 27 TR-2
Stand-by	P_{SB}	kW	0.021	0.021
Crankcase heater mode	P_{CK}	kW	0.055	0.055
Supplementary heater				
Rated heat output	P_{sup}	kW	0.0	0.0
Type of energy input			Electricity	Electricity
Other specifications				
Capacity control			Variable	Variable
Sound power level, indoors - outdoors	L_{WA}	dB	43 - 70	43 - 77
Annual energy consumption under average conditions	Q_{HE}	kWh	7681	9993
Annual energy consumption under colder conditions	Q_{HE}	kWh	10578	13164
Annual energy consumption under warmer conditions	Q_{HE}	kWh	10025	11541
Rated air flow rate, outdoors for air-to-water heat pumps	-	m ³ /h	6000	6000
(1) The rated heat output P_{rated} is equal to the design load for heating $P_{designh}$, and the rated heat output of a supplementary heater P_{sup} is equal to the supplementary capacity for heating $sup(Tj)$. (2) If C_{dh} is not determined by measurement, the default degradation coefficient is $C_{dh} = 0.9$.				

 **See**
The back cover for contact details.

3.3.4 Circulating pump

 **Important**
The benchmark for the most efficient circulating pumps is $EEL \leq 0.20$.

4 Operation

4.1 Description of the user interface

4.1.1 Description of the user interface

Fig.2

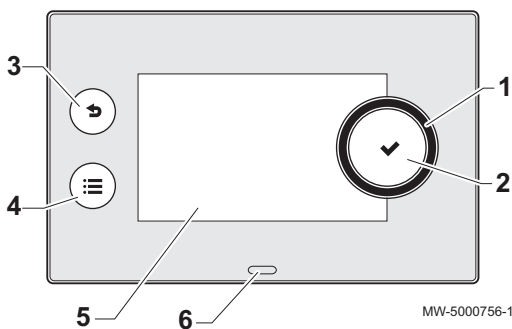

- 1 Rotary knob to select a menu or setting
- 2 Validation button ✓
- 3 Back button ↶ to return to the previous level or menu
- 4 Main menu button ☰
- 5 Display screen
- 6 LED for status indication:
 - continuous green = normal operation
 - flashing green = warning
 - red fixed = blockage
 - flashing red = lockout

4.1.2 Description of the home screen

The home screen is displayed automatically after the appliance is started up.

The screen automatically goes into standby if no button is pressed for five minutes.

Press one of the buttons on the user interface to exit the standby screen and display the home screen.

Tab.13 Icons on the home screen and information

Icon	Information	Description of the icon
	Error status	Information on operation of the appliance
	Maintenance status	Maintenance message
	Installer access	Installer Level
	Holiday programme	Holiday mode in all circuits simultaneously
	Air source heat pump	Heat pump flow temperature display
	Water pressure	Current water pressure display
	CIRCA/CIRCB	Symbol representing the circuit used Circuit temperature display
	DHW tank	Temperature display for the domestic hot water
	Outdoor temperature	Outdoor temperature display

4.2 Starting and stopping the heat pump

4.2.1 Starting the heat pump

1. Switch on the outdoor unit and the indoor unit.
⇒ The heat pump will begin an automatic vent cycle (which lasts approx. three minutes), run each time the power is switched on.
2. Check the hydraulic pressure in the installation indicated on the user interface.



Important

Recommended hydraulic pressure between 1.5 and 2.0 bar.

4.2.2 Shutting down the heat pump

The heat pump must be shut down in certain situations, for example during any intervention on the equipment. In other situations, such as an extended absence period, we recommend that the **Holiday** operating mode is used in order to benefit from the heat pump anti-blocking function and to protect the installation from frost.

To shut down the heat pump:

1. Switch off the power to the outdoor unit.
2. Switch off the power to the indoor unit.

4.3 Switching the central heating on/off

Your appliance will automatically deactivate the heating function and switch to cooling mode when the temperature exceeds 22 °C (factory setting). However, you can manually switch off the heating function for all circuits to save energy during the summer period, for example.



Important

If the heating function is shut off, then the cooling will also be shut off.



1. Select the **Air Src Heat pump** icon.
2. Select **CH function on**.
3. Select the desired value:
 - **Off** to stop the heating function.
 - **On** to switch the heating function on again.

4.4 Periods of absence or going on holiday

If you will be absent for several weeks, you can reduce the room temperature and domestic hot water temperature in order to save energy. To do this, activate the **Holiday** operating mode for all zones, including for domestic hot water.



1. Select the **Holiday Mode** icon.
2. Set the following parameters:

Tab.14

Parameter	Description
Start date holiday	Set the date and time for the start of the absence period.
End date holiday	Set the date and time for the end of the absence period.
Wished room temperature during holiday	Set the desired room temperature for the absence period
Reset	Restart or cancel the holiday programme

4.5 Regional and ergonomic parameters

You can personalise your appliance by modifying the parameters linked to your geographic location and the ergonomics of the user interface.



1. Press the  button.
2. Select **System Settings**.
3. Carry out one of the following operations:

Tab.15

Menu	Description
Set Date and Time	Setting the date and time
Select Country and Language	Select the country and language
Daylight Saving Time	Setting the automatic change to daylight saving time. These changes will be carried out on the last Sunday in March and October
Installer Details	Display the installer details
Cost calculation	Enter the tariffs for the energy used
Set Heating Activity Names	Modify the name of activities used to program heating periods
Set Cooling Activity Names	Modify the name of activities used to program cooling periods
Set Screen Brightness	Setting the screen brightness
Set click sound	Switch the sound of the rotary knob on or off
Firmware Update	Function not available
License Information	Display the creation licenses for the internal software

4.6 Personalising the zones

4.6.1 Definition of the term "zone"

Fig.3

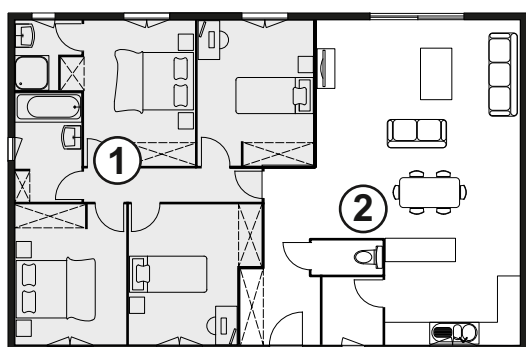

MW-1001145-2

Zone: term given to the different hydraulic circuits (CIRCA, CIRCB). It indicates several rooms served by the same circuit.

Tab.16 Example:

Key	Zone	Factory-set name
①	Zone 1	CIRCA
②	Zone 2	CIRCB

4.6.2 Changing the name and symbol of a zone

The name and symbol for a zone are factory-set as shown in the appendix. If you desire, you can personalise the name and symbol of the zones in your installation.

1. Select the icon of the zone to be modified, , for example.
2. Select **Zone configuration > Zone friendly Name**.
3. Change the name of the zone (20 characters maximum).
4. Select **Icon display zone**
5. Select the symbol to be associated with the zone.
6. Enter the chosen name and symbol in the table provided at the back of the manual.

4.7 Personalising the activities

4.7.1 Definition of the term "Activity"

Activity: this term is used when programming time ranges. It refers to the client's desired comfort level for different activities during the course of the day. One set point temperature is associated to each activity. The last activity of the day remains valid until the first activity of the following day.

Fig.4

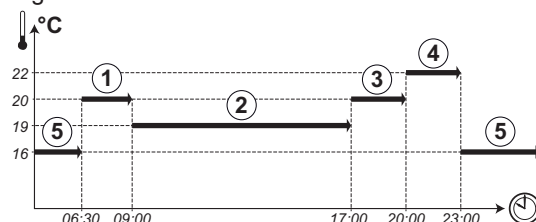

MW-1001144-2

Tab.17 Example:

Start of the activity	Activity	Set point temperature
6:30	Morning ①	20 °C
9:00	Away ②	19 °C
17:00	Home ③	20 °C
20:00	Evening ④	22 °C
23:00	Sleep ⑤	16 °C

4.7.2 Changing the name of an activity

The name of the different activities is factory-set: Sleep, Home, Away, Morning, Evening and Custom. If you wish, you can personalise the name of the activities for all of the zones in your installation.

1. Press the  button.
2. Select **System Settings**.

3. Select **Set Heating Activity Names** or **Set Cooling Activity Names**.
4. Select the activity you want to change.
5. Change the name of the activity (10 characters max.).

4.7.3 Changing the temperature of an activity

The temperatures for the different activities are factory-set as shown in the appendix. If you desire, you can personalise the temperatures for these activities for all of the zones in your installation. These activities are used in the timer programmes.

1. Select the icon for the zone to be programmed, , for example.
2. Select **Set Heating Activity Temperatures**, either for heating or for cooling.
⇒ Information on the selected menu is given in the lower part of the screen.
3. Select the activity you want to change.
4. Modify the temperature for the activity.
5. Enter the chosen temperature in the table provided at the back of the manual.

4.8 Room temperature for a zone





4.8.1 Selecting the operating mode

To set the room temperature for the different living zones, you can choose between five operating modes. We recommend the **Scheduling** operating mode which enables the room temperature to be modulated according to your needs and to optimise your energy consumption.



1. Select the icon for the affected zone, , for example.
2. Select the desired operating mode:

Tab.18

Mode	Description
 Scheduling	The room temperature is modulated according to the timer programme chosen. Recommended mode.
 Manual	The room temperature is constant.
 Short temperature change	The room temperature is forced for a defined period.
 Holiday	The room temperature is reduced during an absence period to save energy.
 Antifrost	The installation and equipment are protected against frost during the winter period.

4.8.2 Activating and configuring a timer programme for heating

A timer programme can be used to vary the room temperature in a living zone depending on activities during the day. This can be programmed for each day of the week.



1. Select the icon for the zone to be programmed, , for example.
⇒ Information on the current operating mode is given in the upper part of the screen.
2. To activate the timer programming or to change the timer programme, select **Scheduling**.
3. Select the timer programme to be activated.
⇒ Information on the active timer programme is given in the upper part of the screen.

Fig.5



4. To modify the timer programme, select **Zone configuration > Heating Schedule**.
5. Select the programme to be modified.
 - ⇒ The programmed activities for Monday are displayed. The last activity of the day remains active until the first activity of the following day.
6. Select the day to be modified.
7. Carry out the following actions according to your needs:
 - **Modify** the timings for programmed activities.
 - **Add** a new time range.
 - **Delete** a programmed activity (choose the activity "Delete").
 - **Copy** programmed daily activities to other days.
 - **Modify temperatures** linked to an activity.

4.8.3 Activating and configuring a timer programme for cooling

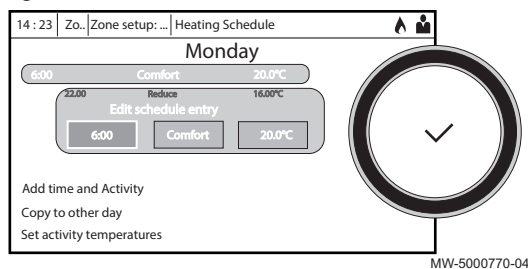
You can modify the timer programme linked to the **Cooling** mode. In the **Scheduling** operating mode, the Cooling timer programme is activated automatically when the average outdoor temperature over a 24-hour period has been greater than 22 °C. If you would prefer that this mode is triggered at a different temperature, ask your installer to modify this parameter in your installation.



Fig.6

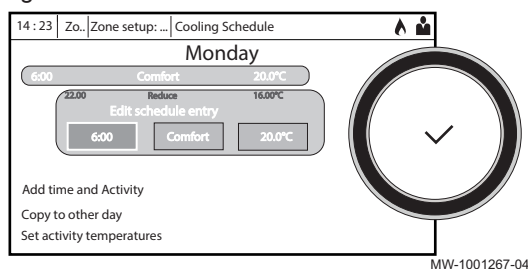

1. Select the icon for the zone to be programmed, , for example.
 - ⇒ Information on the current operating mode is given in the upper part of the screen.
2. To modify the timer programme for the **Cooling** mode, select **Zone configuration > Cooling Schedule**.
 - ⇒ The programmed activities for Monday are displayed. The last activity of the day remains active until the first activity of the following day.
3. Select the day to be modified.
4. Carry out the following actions according to your needs:
 - **Modify** the timings for programmed activities.
 - **Add** a new activity.
 - **Delete** a programmed activity (choose the activity "Delete").
 - **Copy** programmed daily activities to other days.
 - **Modify temperatures** linked to an activity.

4.8.4 Changing the room temperature temporarily

Regardless of the operating mode selected for a zone, it is possible to modify the room temperature for a defined period. Once this time has elapsed, the selected operating mode will restart.



1. Select the icon of the zone to be modified, , for example.
2. Select **Short temperature change**.
3. Define the duration in **Hour** and in **Minute**.
4. Set the temporary room temperature setpoint for the circuit selected.

4.9 Domestic hot water temperature

4.9.1 Selecting the operating mode





For the production of domestic hot water, you can choose between five operating modes. We recommend the **Scheduling** mode which enables domestic hot water production periods to be programmed according to your needs and to optimise your energy consumption.



1. Select the  **DHW tank** icon.

2. Select the desired operating mode:

Tab.19

Mode		Description
	Scheduling	The domestic hot water is produced according to the timer programme chosen
	Manual	The domestic hot water temperature remains at the comfort temperature permanently
	Hot water boost	The production of domestic hot water is forced at the comfort temperature for a defined duration
	Holiday	The domestic hot water temperature is reduced during an absence period to save energy
	Antifrost	The equipment and the system are protected when the heat pump is in frost protection mode.

4.9.2 Activating and configuring a timer programme for domestic hot water

A timer programme can be used to vary the domestic hot water temperature depending on activities during the day. This can be programmed for each day of the week.



1. Select the **DHW tank icon**.
⇒ Information on the current operating mode is given in the upper part of the screen.
2. To activate the timer programming or to change the timer programme, select **Scheduling**.
3. Select the timer programme to be activated.
⇒ Information on the active timer programme is given in the upper part of the screen.
4. To modify the timer programme, select **Zone configuration > DHW Schedule**.
5. Select the programme to be modified.
⇒ The programmed activities for Monday are displayed.
The last activity of the day remains active until the first activity of the following day.
6. Select the day to be modified.
7. Carry out the following actions according to your needs:
 - **Modify** the timings for programmed activities.
 - **Add** a new activity.
 - **Delete** a programmed activity (choose the activity "Delete").
 - **Copy** programmed daily activities to other days.
 - **Modify temperatures** linked to an activity.

Fig.7

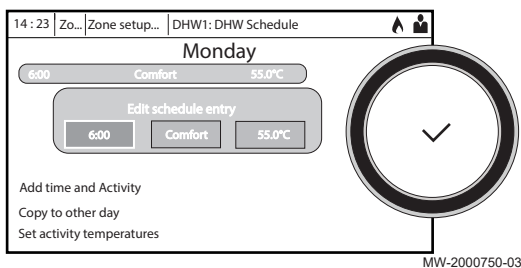

4.9.3 Forcing domestic hot water production (override)

Regardless of the selected operating mode, you can force domestic hot water production to the comfort temperature (**DHW comfort setpoint** parameter) for a defined duration.



1. Select the **DHW tank icon**.
2. Select **Hot water boost**.
3. Define the duration in **Hour** and in **Minute**.

4.9.4 Modifying the domestic hot water set point temperatures

The production of domestic hot water operates with two set point temperature parameters:

- **DHW comfort setpoint**: used in the Scheduling, Manual and Hot water boostmodes
- **DHW reduced setpoint**: used in the Scheduling, Holiday and Antifrostmodes

You can change these set point temperature settings to adapt them to your needs.



1. Select the **DHW tank icon**.
2. Select **Comfort DHW set point** to modify this set point.
3. Select **Zone configuration > Domestic Hot Water Setpoints > Reduced DHW set point** to modify this set point.

4.10 Monitoring the energy consumption

If your installation is equipped with an energy meter, you can monitor your energy consumption.



1. Select the **Air Src Heat pump icon**.
⇒ The energy consumed since the last energy consumption meter reset is displayed:

Tab.20

Parameter	Description
Cool Energy consumed	Energy consumed for cooling
DHW energy consumed	Energy consumed for domestic hot water
CH Energy Consumed	Energy consumed for central heating

2. To reset the meters to zero, select **Reset counters for the energy consumption**.

5 Maintenance

5.1 General

An annual inspection with a leak-tightness check in accordance with prevailing standards is obligatory.

Maintenance operations are important for the following reasons:

- To guarantee optimum performance.
- To extend the life of the equipment.
- To provide an installation which offers the user optimum comfort over time.



Caution

Only qualified professionals are authorised to carry out maintenance work on the heat pump and the heating system.



Danger of electric shock

Before any work, switch off the power supply to the heat pump and the backup boiler or the electric heating element, if present.



Caution

Before working on the refrigeration circuit, switch off the appliance and wait a few minutes. Certain items of equipment such as the compressor and the pipes can reach temperatures in excess of 100°C and high pressures, which may cause serious injuries.



Caution

Do not drain the installation, except in cases of absolute necessity. E.g.: several months' absence with the risk of temperatures in the building falling below freezing.



Important

- Maintenance shall be performed only as recommended by the manufacturer.
- Replace any damaged component.
- When breaking into the refrigerant circuit to make repairs – or for any other purpose – remove the refrigerant. Recover the refrigerant into the correct recovery cylinders.

5.2 Standard inspection and maintenance operations

An annual inspection with tightness check is obligatory. These maintenance operations are necessary in order to guarantee the performance of the installation and to extend the life of the equipment.



Caution

Only qualified professionals are authorised to carry out maintenance work on the heat pump and the heating system.

Schedule a service by a qualified professional at a cold time of the year to check the following points:

1. Operation of the installation.
2. Thermal output, by measuring the difference in temperature between heating flow and return.
3. The setting for the safety thermostats.

5.3 Maintenance message

When a maintenance operation is required, your appliance will alert you in two ways:

- A maintenance message will appear on the screen.
- The **Maintenance Status** icon on the home screen flashes.

5.4 Displaying the maintenance information

Your appliance gives you information on necessary maintenance and servicing operations.



1. Select the **Maintenance Status** icon.
2. Consult the information linked to the maintenance and servicing of your appliance:

Information	Description
Maintenance required	Indicates the necessity of maintenance: yes/no
Current maintenance	Type of maintenance to come
Service run hours	Number of hours that the appliance has been producing energy since last service
Hours since service	Number of hours since the previous servicing of the appliance
Starts since service	Number of heat generator starts since the previous servicing.

5.5 Check the hydraulic pressure

Regularly check the hydraulic pressure in the installation. It should be between 1.5 and 2 bar.



1. Select the **Water Pressure** icon.
2. Check the pressure that is displayed in the right section of the main screen.
3. If the pressure is less than 1.5 bar, contact the installer so that they check the condition of the expansion vessel, check hydraulic leak-tightness and top up the water.

5.6 Cleaning the casing

1. Clean the outside of the appliance using a damp cloth and a mild detergent.

6 Troubleshooting

6.1 Resolving operating errors

If your appliance malfunctions, the status LED flashes and/or changes colour and a message containing an error code is displayed on the user interface screen. This error code is important for the correct and rapid diagnosis of the type of malfunction and for any technical assistance that may be needed.

If an error occurs:

1. Make a note of the code displayed on the screen.
2. Remedy the problem described by the error code or contact the installer.
3. Switch the heat pump off and back on to check that the cause of the error has been removed.
4. If the code is displayed again, contact the installer.

6.1.1 Types of error code

The user interface can display three types of error code:

Tab.21

Type of code	Code format	Colour of the status LED
Warning	Axx.xx	Green flashing
Blockage	Hxx.xx	Continuous red
Lockout	Exx.xx	Flashing red

6.1.2 Blocking codes

A blocking code signals an anomaly affecting the heating system.

Several examples:

- The system automatically attempts to correct the error (for example in the event of a fault related to the flow rate).
- The error is still present and the system functions in defect mode (for example, in the event of a fault affecting the outdoor unit, the backup is started up).
- The system is shut down but automatically switches on again when the error disappears.

When one of the codes below is displayed, contact the professional responsible for maintenance of the heat pump.

Tab.22 List of blocking codes linked to the EHC-05 PCB

Code	Message	Description
H00.17	DHW sensor Closed	Domestic Hot Water tank temperature sensor is either shorted or measures a temperature above range
H00.32	TOutside Open	Outside temperature sensor is either removed or measures a temperature below range

Code	Message	Description
H00.33	TOutside Closed	Outside temperature sensor is either shorted or measures a temperature above range
H00.34	TOutside Missing	Outside temperature sensor was expected but not detected
H00.47	HP flow sensor removed or below range	Heat pump flow temperature sensor is either removed or measures a temperature below range
H00.48	THp Flow Closed	Heat pump flow temperature sensor is either shorted or measures a temperature above range
H00.49	THp Flow Missing	Heat pump flow temperature sensor was expected but not detected
H00.51	THp Return Open	Heat pump return temperature sensor is either removed or measures a temperature below range
H00.52	THp Return Closed	Heat pump return temperature sensor is either shorted or measures a temperature above range
H00.57	T DHW Top Open	Domestic Hot Water top temperature sensor is either removed or measures a temperature below range
H00.58	T DHW Top Closed	Domestic Hot Water top temperature sensor is either shorted or measures a temperature above range
H02.02	Wait Config Number	Waiting For Configuration Number
H02.03	Conf Error	Configuration Error
H02.04	Parameter Error	Parameter Error
H02.05	CSU CU mismatch	CSU does not match CU type
H02.07	Water Press Error	Water Pressure Error active <ul style="list-style-type: none"> • Check the hydraulic pressure in the heating circuit.
H02.09	Partial block	Partial blocking of the device recognized BL input on the central unit PCB terminal block open
H02.10	Full Block	Full blocking of the device recognized BL input on the central unit PCB terminal block open
H02.23	System flow error	System water flow error active Flow problem Insufficient flow: open a radiator valve. The circuit is clogged: <ul style="list-style-type: none"> • Check that the filters are not obstructed and clean them if necessary. • Clean and flush the installation. No circulation: <ul style="list-style-type: none"> • Check that the valves and thermostatic valves are open, • Check that the circulating pump is working, • Check the wiring, • Check the pump supply: if the pump does not work, replace it.
H02.25	ACI error	Titan Active System short-circuited or on an open circuit
H02.36	Funct device lost	Functional device has been disconnected No communication between the central unit PCB and the additional circuit PCB
H02.37	Uncritic device lost	Uncritical device has been disconnected No communication between the central unit PCB and the additional circuit PCB
H02.60	Unsupported function	The zone doesn't support the selected function
H06.01	HP Unit Failure	Heat Pump Unit Failure occurred Heat pump outdoor unit fault

6.1.3 SCB-10 blocking codes

A blocking code signals an anomaly affecting the heating system.

Several examples:

- The system automatically attempts to correct the error (for example in the event of a fault related to the flow rate).
- The error is still present and the system functions in defect mode (for example, in the event of a fault affecting the outdoor unit, the backup is started up).
- The system is shut down but automatically switches on again when the error disappears.

When one of the codes below is displayed, contact the professional responsible for maintenance of the heat pump.

Tab.23 List of blocking codes linked to the SCB-10 PCB

Code	Message	Description
H00.69	TbufferTankOpen	Buffer Tank temperature sensor is either removed or measures a temperature below range
H00.70	TbufferTankClosed	Buffer Tank temperature sensor is either shorted or measures a temperature above range
H00.71	TbufferTankTopOpen	Buffer Tank top temperature sensor is either removed or measures a temperature below range
H00.72	TbufferTankTopClosed	Buffer Tank top temperature sensor is either shorted or measures a temperature above range
H00.74	TBufferTankMissing	Buffer Tank temperature sensor was expected but not detected
H00.75	TBufferTankTop Miss	Buffer Tank Top temperature sensor was expected but not detected
H00.76	TcascadeFlow Open	Cascade Flow temperature sensor is either removed or measures a temperature below range
H00.77	TcascadeFlow Closed	Cascade Flow temperature sensor is either shorted or measures a temperature above range
H00.78	TcascadeFlow missing	Cascade Flow temperature sensor was expected but not detected
H02.02	Wait Config Number	Waiting For Configuration Number
H02.03	Conf Error	Configuration Error
H02.04	Parameter Error	Parameter Error
H02.05	CSU CU mismatch	CSU does not match CU type
H02.16	Int CSU Timeout	Internal CSU Timeout
H02.36	Funct device lost	Functional device has been disconnected
H02.40	Function unavailable	Function unavailable
H02.45	Full Can Conn Matrix	Full Can Connection Matrix
H02.46	Full Can Device Adm	Full Can Device Administration
H02.47	Failed Conn Funct Gr	Failed Connecting Function Groups
H02.48	Funct Gr Conf Fault	Function Group Configuration Fault
H02.49	Failed Init Node	Failed Initialising Node
H02.55	Inval or miss SerNR	Invalid or missing device serial number
H02.61	Unsupported function	Zone A doesn't support the selected function
H02.62	Unsupported function	Zone B doesn't support the selected function
H02.63	Unsupported function	Zone C doesn't support the selected function
H02.64	Unsupported function	Zone D doesn't support the selected function
H02.65	Unsupported function	Zone E doesn't support the selected function
H02.66	TAS not connected	The anti corrosion protection (TAS) of the Domestic Hot Water tank is not connected
H02.67	TAS short-circuit	The anti corrosion protection (TAS) of the Domestic Hot Water tank is shortend
H10.00	T Flow Zone A Open	Flow temperature sensor Zone A Open
H10.01	T Flow Zone A Closed	Flow temperature sensor Zone A Closed
H10.02	T DhW Zone A Open	Domestic Hot Water temperature sensor Zone A Open
H10.03	T DhW Zone A Closed	Domestic Hot Water temperature sensor Zone A Closed
H10.04	TSwimmPoolZoneA Open	Swimming Pool Temperature Sensor Zone A Open
H10.05	TSwimmPoolZoneAClose	Swimming Pool Temperature Sensor Zone A Closed
H10.09	T Flow Zone B Open	Flow temperature sensor Zone B Open
H10.10	T Flow Zone B Closed	Flow temperature sensor Zone B Closed
H10.11	T DhW Zone B Open	Domestic Hot Water Temperature Sensor Zone B Open
H10.12	T DhW Zone B Closed	Domestic Hot Water temperature sensor Zone B Closed
H10.13	TSwimmPoolZoneB Open	Swimming Pool Temperature Sensor Zone B Open

Code	Message	Description
H10.14	TSwimmPoolZoneBClose	Swimming Pool Temperature Sensor Zone B Closed
H10.18	T Flow Zone C Open	Flow temperature sensor Zone C Open
H10.19	T Flow Zone C Closed	Flow temperature sensor Zone C Closed
H10.20	T Dhw Zone C Open	Domestic Hot Water Temperature Sensor Zone C Open
H10.21	T Dhw Zone C Closed	Domestic Hot Water temperature sensor Zone C Closed
H10.22	TSwimmPoolZoneC Open	Swimming Pool Temperature Sensor Zone C Open
H10.23	TSwimmPoolZoneCClose	Swimming Pool Temperature Sensor Zone C Closed
H10.27	T Flow Zone DHW open	Flow temperature sensor Zone DHW open
H10.28	Sens. ZoneDHW closed	Flow temperature sensor Zone DHW closed
H10.29	Sensor Zone DHW open	Temperature sensor Zone DHW open
H10.30	T Zone DHW closed	Domestic Hot Water temperature sensor Zone DHW closed
H10.36	Sensor Zone AUX open	Flow temperature sensor Zone AUX open
H10.37	Sens. ZoneAUX closed	Flow temperature sensor ZoneAUX closed
H10.38	T Dhw Zone AUX open	Domestic Hot Water temperature sensor Zone AUX open
H10.39	Sens. ZoneAUX Closed	Domestic Hot Water temperature sensor Zone AUX closed

6.1.4 Lockout codes

A lockout code signals a major anomaly affecting the heating system: the heating system is shut down as the safety conditions are not fulfilled.

When one of the codes below is displayed, contact the professional responsible for maintenance of the heat pump.

Tab.24 List of lockout codes

Code	Message	Description
E00.00	TFlow Open	Flow temperature sensor is either removed or measures a temperature below range
E00.01	TFlow Closed	Flow temperature sensor is either shorted or measures a temperature above range
E02.13	Blocking Input	Blocking Input of the Control Unit from device external environment Input BL open.
E02.24	System flow locking	System water flow locking active Insufficient flow: open a radiator valve The circuit is clogged: <ul style="list-style-type: none"> • Check that the filters are not obstructed and clean them if necessary. • Clean and flush the installation. No circulation: <ul style="list-style-type: none"> • Check that the valves and thermostatic valves are open. • Check that the filters are not obstructed. • Check that the circulating pump is working. • Check the wiring. • Check the pump supply: if the pump does not work, replace it.

6.1.5 Warning codes

A warning code signals that the optimal operating conditions are not fulfilled. The system continues to operate safely, but there is a risk of shutdown if the situation continues to deteriorate.

If the situation improves, the warning code may disappear spontaneously.

When one of the codes below is displayed continuously, contact the professional responsible for maintenance of the heat pump.

Tab.25 List of warning codes linked to the EHC-05 PCB

Code	Message	Description
A02.06	Water Press Warning	Water Pressure Warning active
A02.18	OBD Error	Object Dictionary Error

Code	Message	Description
A02.22	System flow warning	System water flow warning active
A02.55	Inval or miss SerNR	Invalid or missing device serial number
A02.80	Missing Cascade Ctrl	Missing Cascade controller

6.1.6 SCB-10 warning codes

A warning code signals that the optimal operating conditions are not fulfilled. The system continues to operate safely, but there is a risk of shutdown if the situation continues to deteriorate.

If the situation improves, the warning code may disappear spontaneously.

When one of the codes below is displayed continuously, contact the professional responsible for maintenance of the heat pump.

Tab.26 List of warning codes linked to the SCB-10 PCB

Code	Message	Description
A00.32	TOutside Open	Outside temperature sensor is either removed or measures a temperature below range
A00.33	TOutside Closed	Outside temperature sensor is either shorted or measures a temperature above range
A00.34	TOutside Missing	Outside temperature sensor was expected but not detected
A02.18	OBD Error	Object Dictionary Error:
A02.37	Uncritic device lost	Uncritical device has been disconnected:
A10.45	RoomTempZoneA miss	Measure of Room Temperature Zone A is missing
A10.46	RoomTempZoneB miss	Measure of Room Temperature Zone B is missing
A10.47	RoomTempZoneC miss	Measure of Room Temperature Zone C is missing
A10.50	T_DHW top D miss	Domestic Hot Water temperature sensor top zone DHW is missing
A10.54	Temp. Zone DHW miss.	Temperature sensor Zone DHW is missing
A10.56	T_DHW Zone AUX miss	Domestic Hot Water temperature sensor Zone AUX is missing

6.2 Fault finding

Tab.27

Problems	Probable causes	Corrections
The radiators are cold.	The heating setpoint temperature is too low.	Increase the value of the room temperature setpoint or, if a room unit is connected, increase the temperature on it.
	The heating mode is deactivated.	Activate the heating mode.
	The radiator valves are closed.	Open the valves on all radiators connected to the heating system.
	The heat pump is not operating.	<ul style="list-style-type: none"> • Check that the heat pump is switched on. • Check the fuses and switches on the electrical installation.
	The water pressure is too low (< 1 bar).	Top up the system with water.

Problems	Probable causes	Corrections
There is no domestic hot water.	The domestic hot water setpoint temperature is too low.	Increase the domestic hot water setpoint temperature.
	The domestic hot water mode is deactivated.	Activate the domestic hot water mode.
	The appliance is in reduced domestic hot water mode	<ul style="list-style-type: none"> • Check and modify the comfort and reduced time ranges for the domestic hot water. • Adapt the domestic hot water setpoint temperature.
	The shower head is restricting the water flow.	Clean the shower head; replace it if necessary.
	The heat pump is not operating.	<ul style="list-style-type: none"> • Check that the heat pump is switched on. • Check the fuses and switches on the electrical installation.
	The water pressure is too low (< 1 bar).	Top up the installation with water.
Significant variations in domestic hot water temperature	Insufficient water supply	<ul style="list-style-type: none"> • Check the water pressure in the installation. • Open the valve.
	The domestic hot water hysteresis is too high	Contact the professional responsible for maintenance of the heat pump.
The heat pump does not work.	The heating setpoint temperature is too low.	Increase the value of the room temperature setpoint or, if a room unit is connected, increase the temperature on it.
	The heat pump is not operating.	<ul style="list-style-type: none"> • Check that the heat pump is switched on. • Check the fuses and switches on the electrical installation.
	The water pressure is too low (< 1 bar).	Top up the system with water.
	An error code appears on the display.	Correct the error if possible.
The heat pump runs short-cycling in domestic hot water mode	The temperature setpoint is too low	Increase the setpoint
The water pressure is too low (< 1 bar).	Not enough water in the installation.	Top up the system with water.
	Water leak.	Contact the professional responsible for maintenance of the heat pump.
Clicking in the central heating pipes	The central heating pipe clamps are too tight.	Slightly loosen the clamps.
	There is air in the heating pipes.	Vent any air in the domestic hot water tank, the pipes and the taps to prevent the annoying noises likely to be produced during heating or when drawing off water.
	The water is circulating too quickly in the central heating system.	Contact the professional responsible for maintenance of the heat pump.
Significant water leak underneath or in the vicinity of the heat pump.	The pipes on the heat pump or the central heating are damaged.	Contact the professional responsible for maintenance of the heat pump.

7 Decommissioning and disposal

7.1 Decommissioning procedure

To decommission the heat pump temporarily or permanently:

1. Contact the installer.

7.2 Disposal and recycling

Fig.8



Warning

Removal and disposal of the heat pump must be carried out by a qualified professional in accordance with prevailing local and national regulations.

8 Energy savings

Energy-saving advice:

- Do not block ventilation outlets.
- Do not cover the radiators. Do not fit curtains in front of the radiators.
- Install reflective panels behind the radiators to prevent heat losses.
- Insulate the pipes in rooms that are not heated (cellars and lofts).
- Close the radiators in rooms not in use.
- Do not run hot (or cold) water pointlessly.
- Install an energy-saving shower head, which can save up to 40 % energy.
- Take showers rather than baths. A bath consumes twice as much water and energy.

9 Product fiche and package fiche

9.1 Compatible heating devices

Tab.28

Outdoor unit	Associated/compatible indoor units
AWHP 4.5 MR	MIT-S 4-8/E MIT-S 4-8/H
AWHP 6 MR-3	MIT-S 4-8/E MIT-S 4-8/H
AWHP 8 MR-2	MIT-S 4-8/E MIT-S 4-8/H
AWHP 11 MR-2	MIT-S 11-16/E MIT-S 11-16/H
AWHP 11 TR-2	MIT-S 11-16/E MIT-S 11-16/H
AWHP 16 MR-2	MIT-S 11-16/E MIT-S 11-16/H
AWHP 16 TR-2	MIT-S 11-16/E MIT-S 11-16/H
AWHP 22 TR-2	MIT-S 22-27/E MIT-S 22-27/H
AWHP 27 TR-2	MIT-S 22-27/E MIT-S 22-27/H

9.2 Product fiche

Tab.29 Product fiche for heat pump space heaters

	Unit	AWHP 4.5 MR	AWHP 6 MR-3	AWHP 8 MR-2
Space heating energy efficiency class under average climate conditions		A ⁺⁺	A ⁺⁺	A ⁺⁺
Rated heat output under average climate conditions (<i>Prated or Psup</i>)	kW	3	4	6

	Unit	AWHP 4.5 MR	AWHP 6 MR-3	AWHP 8 MR-2
Seasonal space heating energy efficiency under average climate conditions	%	134	125	129
Annual energy consumption under average climate conditions	kWh	2353	2124	3499
Sound power level L_{WA} indoors ⁽¹⁾	dB (A)	43	43	51
Rated heat output, under colder - warmer climate conditions	kW	5 - 4	4 - 5	6 - 6
Seasonal space heating energy efficiency, under colder - warmer climate conditions	%	109 - 179	116 - 172	119 - 169
Annual energy consumption, under colder - warmer climate conditions	kWh	4483 - 1249	3721 - 1492	4621 - 1904
Sound power level L_{WA} outdoors	dB (A)	58	65	65
(1) If applicable				

Tab.30 Product fiche for heat pump space heaters

	Unit	AWHP 11 MR-2	AWHP 11 TR-2	AWHP 16 MR-2	AWHP 16 TR-2
Space heating energy efficiency class under average climate conditions		A⁺⁺	A⁺⁺	A⁺	A⁺
Rated heat output under average climate conditions (<i>Prated or Psup</i>)	kW	6	6	9	9
Seasonal space heating energy efficiency under average climate conditions	%	125	125	121	121
Annual energy consumption under average climate conditions	kWh	3999	3999	5861	5861
Sound power level L_{WA} indoors ⁽¹⁾	dB (A)	51	51	51	51
Rated heat output, under colder - warmer climate conditions	kW	4 - 8	4 - 8	7 - 13	7 - 13
Seasonal space heating energy efficiency, under colder - warmer climate conditions	%	113 - 167	113 - 167	113 - 161	113 - 161
Annual energy consumption, under colder - warmer climate conditions	kWh	3804 - 2580	3804 - 2580	5684 - 4120	5684 - 4120
Sound power level L_{WA} outdoors	dB (A)	65	65	69	69
(1) If applicable.					

Tab.31 Product fiche for heat pump space heaters

	Unit	AWHP 22 TR-2	AWHP 27 TR-2
Space heating energy efficiency class under average climate conditions		A⁺	A⁺
Rated heat output under average climate conditions (<i>Prated or Psup</i>)	kW	11	14
Seasonal space heating energy efficiency under average climate conditions	%	114	112
Annual energy consumption under average climate conditions	kWh	7681	9993
Sound power level L_{WA} indoors ⁽¹⁾	dB (A)	43	43
Rated heat output, under colder - warmer climate conditions	kW	12 - 18	14 - 20
Seasonal space heating energy efficiency, under colder - warmer climate conditions	%	111 - 143	103 - 141
Annual energy consumption, under colder - warmer climate conditions	kWh	10578 - 10025	13164 - 11541
Sound power level L_{WA} outdoors	dB (A)	70	77
(1) If applicable.			



See

For specific precautions about assembling, installing and maintaining: See Safety

9.3 Product fiche – Temperature controller

Tab.32 Product fiche for the temperature controller

	Unit	DIEMATIC Evolution
Class		II
Contribution to space heating energy efficiency	%	2

9.4 Package fiche - Medium-temperature heat pumps



Important

'Medium-temperature application' means an application where the heat pump space heater or heat pump combination heater delivers its declared capacity for heating at an indoor heat exchanger outlet temperature of 55 °C.

Fig.9 Package fiche for medium-temperature heat pumps indicating the space heating energy efficiency of the package

Seasonal space heating energy efficiency of heat pump ①
‘I’ %

Temperature control
 from fiche of temperature control

Class I = 1%, Class II = 2%, Class III = 1.5%,
 Class IV = 2%, Class V = 3%, Class VI = 4%,
 Class VII = 3.5%, Class VIII = 5%

②
 + %

Supplementary boiler
 from fiche of boiler

Seasonal space heating energy efficiency (in %)

③
 (- ‘I’) x ‘II’ = ± %

Solar contribution
 from fiche of solar device

Collector size (in m²)

Tank volume (in m³)

Collector efficiency (in %)

Tank rating ⁽¹⁾
 A* = 0.95, A = 0.91,
 B = 0.86, C = 0.83,
 D - G = 0.81

④
 (‘III’ x + ‘IV’ x) x 0.45 x (/100) x = + %

(1) If tank rating is above A, use 0.95

Seasonal space heating energy efficiency of package under average climate ⑤
 %

Seasonal space heating energy efficiency class of package under average climate

<input type="checkbox"/>	<input type="checkbox"/>	<input type="checkbox"/>	<input type="checkbox"/>	<input type="checkbox"/>	<input type="checkbox"/>	<input type="checkbox"/>	<input type="checkbox"/>	<input type="checkbox"/>	<input type="checkbox"/>
G	F	E	D	C	B	A	A*	A**	A***
<30%	≥30%	≥34%	≥36%	≥75%	≥82%	≥90%	≥98%	≥125%	≥150%

Seasonal space heating energy efficiency under colder and warmer climate conditions

⑤

Colder: - ‘V’ = % **Warmer:** + ‘VI’ = %

The energy efficiency of the package of products provided for in this fiche may not correspond to its actual energy efficiency once installed in a building, as this efficiency is influenced by further factors such as heat loss in the distribution system and the dimensioning of the products in relation to building size and characteristics.

AD-3000745-01

- I The value of the seasonal space heating energy efficiency of the preferential space heater, expressed in %.
- II The factor for weighting the heat output of preferential and supplementary heaters of a package as set out in the following table.
- III The value of the mathematical expression: 294/(11 · Prated), whereby "Prated" is related to the preferential space heater.
- IV The value of the mathematical expression 115/(11 · Prated), whereby "Prated" is related to the preferential space heater.
- V The value of the difference between the seasonal space heating energy efficiencies under average and colder climate conditions, expressed in %.
- VI The value of the difference between the seasonal space heating energy efficiencies under warmer and average climate conditions, expressed in %.

Tab.33 Weighting of medium temperature heat pumps

Prated / (Prated + Psup) ⁽¹⁾⁽²⁾	II, package without hot water storage tank	II, package with hot water storage tank
0	1.00	1.00
0.1	0.70	0.63
0.2	0.45	0.30
0.3	0.25	0.15
0.4	0.15	0.06
0.5	0.05	0.02
0.6	0.02	0
≥ 0.7	0	0

(1) The intermediate values are calculated by linear interpolation between the two adjacent values.
(2) Prated is related to the preferential space heater or combination heater.

Tab.34 Package efficiency

	Unit	AWHP 4.5 MR	AWHP 6 MR-3	AWHP 8 MR-2
Seasonal space heating energy efficiency of package	%	136	127	131

Tab.35 Package efficiency

	Unit	AWHP 11 MR-2	AWHP 11 TR-2	AWHP 16 MR-2	AWHP 16 TR-2	AWHP 22 TR-2	AWHP 27 TR-2
Seasonal space heating energy efficiency of package	%	127	127	123	123	116	114

10 Appendix

10.1 Name and symbol of the zones

Tab.36

Factory-set name	Factory-set symbol	Name and symbol defined by the customer
CIRCA0		
CIRCA1		
CIRCB1		
CIRCC1		
CIRCAUX1		

10.2 Name and temperature of the activities

Tab.37 Name and temperature of the activities for heating

Activities	Factory-set name	Factory-set temperature	Name and temperature defined by the customer
Activity 1	Sleep	16 °C	
Activity 2	Home	20 °C	
Activity 3	Away	6 °C	
Activity 4	Morning	21 °C	
Activity 5	Evening	22 °C	
Activity 6	Custom	20 °C	

Tab.38 Name and temperature of the activities for cooling

Activities	Factory-set name	Factory-set temperature	Name and temperature defined by the customer	
Activity 1	Sleep	30 °C		
Activity 2	Home	25 °C		
Activity 3	Away	25 °C		
Activity 4	Morning	25 °C		
Activity 5	Evening	25 °C		
Activity 6	Custom	25 °C		

© Copyright

All technical and technological information contained in these technical instructions, as well as any drawings and technical descriptions supplied, remain our property and shall not be multiplied without our prior consent in writing. Subject to alterations.

DE DIETRICH

FRANCE

Direction de la Marque
57, rue de la Gare - F-67580 Mertzwiller

☎ 03 88 80 27 00

✉ 03 88 80 27 99

www.dedietrich-thermique.fr

VAN MARCKE NV

BE

LAR Blok Z, 5
B- 8511 KORTRIJK

☎ +32 (0)56/23 75 11

www.vanmarcke.be

DE DIETRICH THERMIQUE IBERIA S.L.U.

ES

C/Salvador Espriu, 11
08908 L'HOSPITALET de LLOBREGAT

☎ +34 902 030 154

@ info@dedietrichthermique.es

www.dedietrich-calefaccion.es

MEIER TOBLER AG

CH

Bahnstrasse 24 - CH - 8603 SCHWERZENBACH

☎ +41 (0) 44 806 41 41

@ info@meiertobler.ch

+41 (0)8 00 846 846 ServiceLine

www.meiertobler.ch

MEIER TOBLER SA

CH

Chemin de la Veyre-d'En-Haut B6,
CH -1806 St-Légier-La-Chiésaz

☎ +41 (0) 21 943 02 22

@ info@meiertobler.ch

+41 (0)8 00 846 846 ServiceLine

www.meiertobler.ch

DE DIETRICH

Technika Grzewcza sp. z o.o.

PL

ul. Północna 15-19, 54-105 Wrocław

☎ +48 71 71 27 400

@ biuro@dedietrich.pl

801 080 881 Infocentrala
0,35 zł / min

www.facebook.com/DeDietrichPL

www.dedietrich.pl

BDR THERMEA (SLOVAKIA) s.r.o.

SK

Hroznová 2318-911 05 Trenčín

☎ +421 907 790 221

@ info@baxi.sk

www.dedietrichsk.sk

De Dietrich

SERVICE CONSOMMATEURS

0 825 120 520 Service 0,15 € / min
+ prix appel

ООО «БДР ТЕРМИЯ РУС»

RU

129164, Россия, г. Москва
Зубарев переулок, д. 15/1
Бизнес-центр «Чайка Плаза», офис 309

☎ 8 800 333-17-18

@ info@dedietrich.ru

www.dedietrich.ru

NEUBERG S.A.

LU

39 rue Jacques Stas - B.P.12
L- 2549 LUXEMBOURG

☎ +352 (0)2 401 401

www.neuberg.lu

www.dedietrich-heating.com

DE DIETRICH SERVICE

AT

☎ 0800 / 201608 freecall

www.dedietrich-heiztechnik.com

DUEDI S.r.l

IT

Distributore Ufficiale Esclusivo
De Dietrich-Thermique Italia Via Maestri del Lavoro, 16
12010 San Defendente di Cervasca (CN)

☎ +39 0171 857170

@ +39 0171 687875

@ info@duediclina.it

www.duediclina.it

DE DIETRICH

CN

UNIT 1006, CBD International
Mansion, No.16 Yong An Dong li,
Chaoyang District, 100022, Beijing China

☎ +400 6688700

@ +86 10 6588 4834

@ contactBJ@dedietrich.com.cn

www.dedietrich-heating.com

BDR THERMEA Czech Republic s.r.o.

CZ

Jeseniova 2770/56 - 130 00 Praha 3

☎ +420 271 001 627

@ dedietrich@bdrthermea.cz

www.dedietrich.cz



POMPE A CHALEUR

www.marque-nf.com



De Dietrich

