

ELENSIO

THERMODYNAMIC WATER HEATER
ENVIRONMENTALLY-FRIENDLY PERFORMANCE



ELENSIO,
PERFORMANT AND ECO-FRIENDLY



**Up to
338 litres**

domestic hot water
volume at 40°C

**Respect for the
environmentally
friendly**

Natural Refrigerant

**100%
MADE IN
FRANCE**

DISCREET PERFORMANCE



- Compact thanks to its very low height, Elenzio integrates discreetly into your home, operating at just 35dB(A)
- With a COP of up to 3.48, ELENSIO delivers 3.48 kWh of heating energy for every 1kWh consumed.
- 100% Made in France.



EXCEPTIONAL DOMESTIC HOT WATER COMFORT



- Up to 338 litres of hot water at 40°C to guarantee domestic hot water comfort for the whole family
- Boost mode forces the heat pump and backup to start up as required to meet significant demand for DHW

THE ENVIRONMENT IS A PRIORITY



- Environmentally-friendly refrigerant R290
- 100% recyclable cardboard packaging
- Zero greenhouse gas emissions to preserve the ozone layer
- Designed as part of an eco-friendly strategy



ELENSIO

QUALITY PRESERVED, LONGEVITY GUARANTEED

- Titanium anode for enamelled tank protection
- Integrated electrical backup
- High-performance exchanger



EASY TO INTEGRATE IN ANY CONFIGURATION

- Small footprint
- Compact
- Its low height means it can be easily installed in a cellar
- Plug'n'Play installation with ambient air or ducted outdoor air

DIMENSIONS

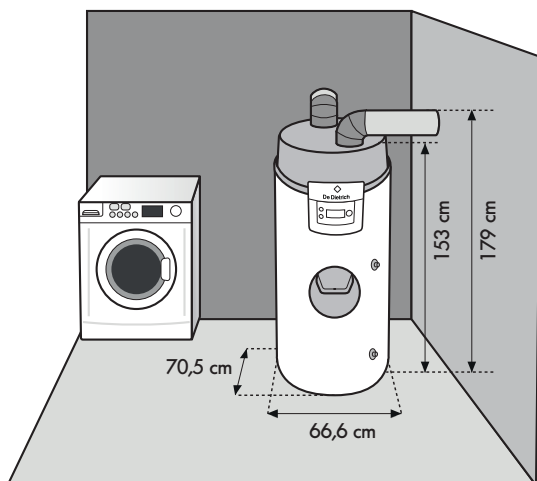

200/200H

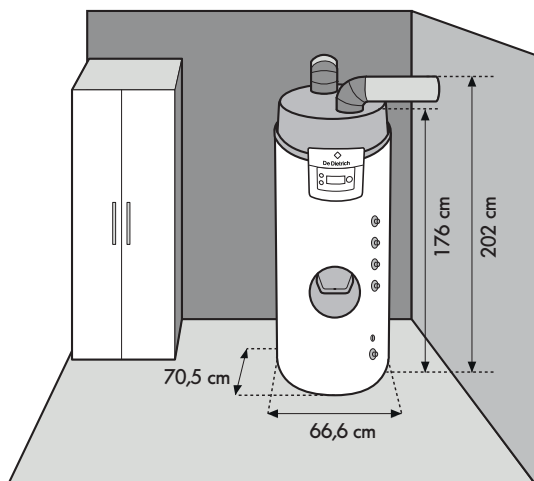

250/250H

COMFORT GUARANTEED WITH RESPECT FOR THE ENVIRONMENT



"We are a family of six and, thanks to Elenzio, I know we'll never be without hot water."

"Because it's compact and very quiet, Elenzio integrates perfectly in our home."

"It was important for us to have an environmentally friendly product."

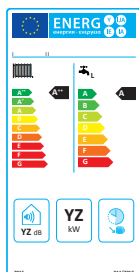













De Dietrich ECO-SOLUTIONS give you the latest generation of multi-energy products and systems: simpler, more efficient and more economical to guarantee your comfort and protect the environment.

The energy label associated with the ECO-SOLUTIONS label indicates the product performance.

www.ecosolutions.dedietrich-heating.com

YOUR HEATING PROJECT

DETERMINE YOUR NEEDS

	200	200H	250	250H				
								
PERFORMANCE								
DOMESTIC HOT WATER USE								
FUNCTIONS								
DRAW-OFF CYCLE AS PER EN16147	M	L	M	L	L	XL	L	XL
BACKUP	ELECTRIC		ELECTRIC/HYDRAULIC		ELECTRIC		ELECTRIC/HYDRAULIC	
MAX MIXED HOT WATER VOLUME AT 40°C	260 L	255 L	258	249 L	337 L	338 L	320 L	318 L
COP (COEFFICIENT OF PERFORMANCE) AT +7°C (OUTDOOR AIR)*	2.56	3.09	2,63	3,15	3.15	3.48	3.00	3.28
SOUND PRESSURE LEVEL**	35DB[A]		35DB[A]		35DB[A]		35DB[A]	
HEAT PUMP OUTPUT	2480 W		2480 W		2480 W		2480 W	
ELECTRICAL BACKUP HEATER	1800 W		1800 W		1800 W		1800 W	
REFRIGERANT/LOADS (KG)	R290/0.150		R290/0.150		R290/0.150		R290/0.150	

*Value obtained with an outdoor air temperature of +7 °C and a water inlet temperature of 10 °C as per LCIE 103-15/C:2018 specifications based on standard NF EN 16147.

**Measured at 2 m



A SYMBOL OF FRENCH QUALITY SINCE 1684

For over three hundred years, De Dietrich's success has been an expectation based on true values: quality, reliability, durability. In the interest of the environment and your comfort, De Dietrich perfectly manages various renewable energies using multi-energy systems to protect the planet. Thanks to the collaboration of our entire team, De Dietrich heating systems have been leading the way in innovation and offering optimal quality and rare longevity for over 300 years.

De Dietrich 

BDR THERMEA FRANCE
S.A.S. with capital of € 229 288 696
57 rue de la Gare - F - 67580 MERTZWILLER
RCS STRASBOURG 833 457 211
www.dedietrich-heating.com

BDR THERMEA GROUP

Your installer