

CFU C - CFU

Oil-fired condensing or standard efficiency boilers



The performance of biofuel at the best price

FRENCH MANUFACTURER
S I N C E 1 6 8 4

De Dietrich 

CFU C - CFU

a new level of energy efficiency

You want to heat
without constraints

CFU C



- Biofuel condensing boiler that replaces your old oil-fired boiler while improving the performance of your installation.
- Up to 25% energy savings thanks to condensation.

CFU



- A biofuel boiler that replaces your old oil-fired boiler.
- Easy to use and maintain.

You want to heat
and produce domestic hot water

CFU C 110 L



- Floor-standing boiler with **110-litre** domestic hot water cylinder positioned under the boiler to form a uniformly attractive **column**.

CFU C 160 L



- Floor-standing boiler with **160-litre** domestic hot water cylinder positioned horizontally under the boiler and positionable **against a wall**.
- For an attractive, uniform column with reduced dimensions.



Efficiency up to 102%

Energy savings of up to 25%

Long-lasting and robust

Intuitive E-Pilot control

Protecting the environment



- Burner in compliance with the ErP directive with low nitrogen oxides emissions (NOx < 120 mg/kWh) responsible for acid rains.
- With low CO₂ emissions and compatibility with BIO FIOUL, it participates in energy transition.
- Equipped with the DUO-PRESS system allowing clean combustion over time thanks to high air pressure at the burner head and high flame stability.

* Except CFU C 19/40/50 : F10



Control panel E-PILOT

- Interface with simplified access to all operation modes and to pop-up menus
- Blue backlight display with pictograms and clear text for better legibility
- Features that make your life easier:
 - Childprotection
 - Holiday function
 - Error alerts directly visible on the home screen
 - Time programming to fit your lifestyle
 - Prioritisation of heating or domestic hot water
- Outdoor temperature sensor as a standard (CFU C Condens models)



Keep control

wherever you are and at any time with an optional connected room thermostat



- Eco-design performance with outdoor sensor and connected room thermostat Smart TC° (wired or radio).



Thanks to its associated Application you will be able to access the following functionalities:

- Remote management of heating, domestic hot water
- Intuitive use
- Programming management according to your needs
- Precise temperature control
- Setting: user help and advanced options
- Maintenance of your installation by your installer will be easy thanks to remote access Secured and at the request of the user
- Malfunction alert directly on your smartphone

Your heating project

Let us guide you according to your needs

Models



CFU C - CFU		CFU C 19	CFU C 24	CFU C 32	CFU C 40	CFU C 50	CFU 22	CFU 29	CFU 36	CFU 46	
Technology		Condensation					Low temperature				
Energy efficiency class											
	combined with 110L and 160L										
Useful output heating mode at 80/60°C	kW	18,3	23,1	30,7	38,5	48,2	22,4	29,8	37,2	46,4	
Useful output mode at 50/30°C	kW	19,3	24,3	32	40,6	50,5	-	-	-	-	
DHW tank to be combined	litre	110 or 160			-	-	110 or 160				

Dimensions

CFU C - CFU

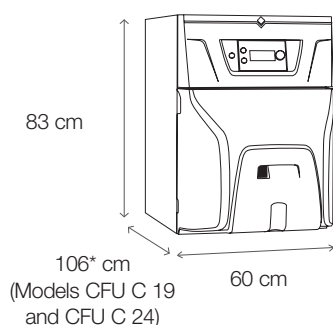

* value varies according to model

CFU C 110 L

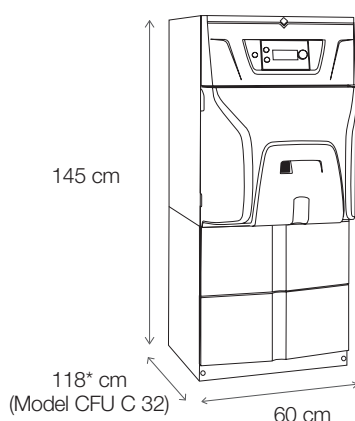

CFU C 160 L

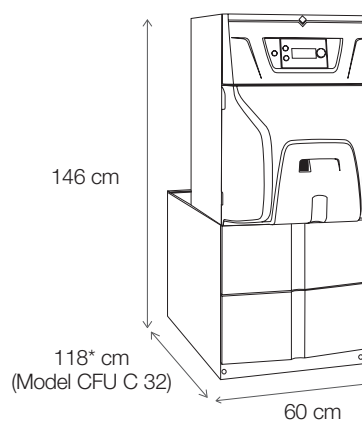

Your installer



BDR THERMEA FRANCE

S.A.S. with corporate capital of 229 288 696 €

57 rue de la Gare - F - 67580 MERTZWILLER
RCS STRASBOURG 833 457 211

www.dedietrich-heating.com



Ref. DDDDEX000015 - 09/2024 - Non-contractual photos. IMPRIM'VERT® Photo credits: Freepik, Adobe stock.

